

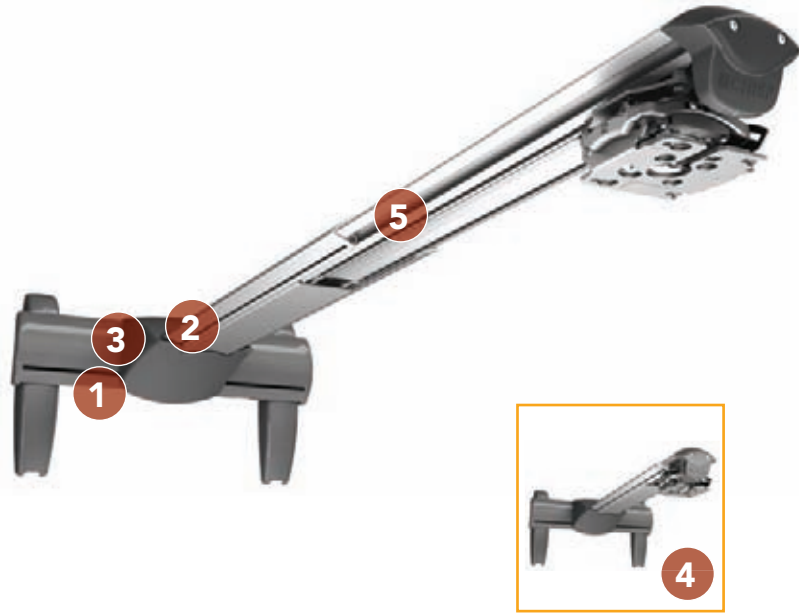

# WALL MOUNTS WM230AUS™ □ SHORT THROW WALL MOUNT



(Includes RSMA™ Mini Projector Mount)

## FEATURES

- 1 LATERAL SHIFT**  
Dual stud design provides up to 10" (254 mm) of lateral shift for quick alignment.
- 2 PRECISION HEIGHT & LEVELING**  
Industry-first micro height and leveling adjustment,  $\pm 3^\circ$ .
- 3 FAST INSTALLATION**  
Innovative quick-connect system.
- 4 VARIABLE EXTENSION OPTIONS**  
Telescoping extension and infinite projector placement make it easy to achieve a picture perfect installation.
- 5 INTEGRATED CABLE MANAGEMENT**  
Fully internal cable management system conceals and protects cables for a clean finish.

## WHAT YOU NEED TO KNOW

### ABOUT WM230S

For use with RSA, RPA, RSMA and RPMA projector mounts. For a complete solution order the kit (WM230AUS™). Kit includes one short throw wall mount accessory plus one RSMAUS projector mount (see page 7).

### OTHER PRODUCT OPTIONS



**WM210S™ / WM210AUS™**  
Wall mount accessory / Kit  
– Max. extension 12.75 - 19.5" (32.3 - 49.5 cm)  
– Weight Cap. 50 lbs (22.7 kg)



**WM220S™ / WM220AUS™**  
Wall mount accessory / Kit  
– Max. extension 17.5 - 30.25" (44.4 - 76.8 cm)  
– Weight Cap. 25 lbs (11.3 kg)

## SPECIFICATIONS

Extension	29.5 - 54.5" (74.9 - 138.4 cm)
Pitch	$\pm 3^\circ$
Lateral Shift	10" (254 mm)
Dimensions (HxWxD)	11.53 x 19.63 x 58.37" (29 x 50 x 148.3 cm)
Weight Capacity	25 lbs (11.3 kg)
Color	Silver

## RECOMMENDED ACCESSORIES



**WMAL24** □ 24" (610 mm) Lateral Shift  
Accessory

## TECHNICAL DRAWINGS

